

 **OMEGA**[®]
FOODTECH



220 GSE
250 GSE - 275 GSE

220/250/275 GSE AFFETTATRICI - SLICING MACHINES - AUFSCHNITTMASCHINEN - TRANCHEUSES - CORTADORAS DE FIAMBRES



AFFETTATRICI A GRAVITÀ
Costruite in lega di alluminio trattata con ossidazione anodica.
Trasmissione a cinghia.
Affilatoio incorporato.
Per il dettaglio e la ristorazione collettiva.
Macchine rispondenti alla Direttiva Macchine 98/37/CEE.
Comandi con dispositivo N.V.R.

GRAVITY SLICING MACHINES
Made of aluminium alloy treated with anodic oxidation.
Belt drive.
Built-in sharpener.
For retail and collective catering.
Machines comply with Machine Directive 98/37/EEC.
Controls with N.V.R. device.

SCHWERKRAFT-AUFSCHNITTMASCHINEN
Ausgeführt aus Aluminiumlegierung, poliert und eloxiert.
Riemenantrieb.
Eingebaute Schleifvorrichtung.
Für Lebensmitteleinzelhandel und Großgastronomie.
Die Maschinen entsprechen der Maschinenrichtlinie 98/37/EWG.
Ein-Aus Drucktaste.

TRANCHEUSES À GRAVITÉ
Réalisées en alliage d'aluminium traité par oxydation anodique.
Transmission à courroie.
Aiguiseur incorporé.
Pour le détail et la restauration collective.
Machine conforme à la Directive machines 98/37/CEE.
Boutons Marche-Arrêt.

CORTADORAS DE FIAMBRES A GRAVEDAD
Costruidas en aleación de aluminio tratada con oxidación anódica.
Transmisión a correa.
Afilador incorporado.
Para venta minorista y restauración colectiva.
Máquinas conformes a la Directiva Máquina 98/37/CEE.
Mandos con dispositivo N.V.R.

Specifiche tecniche / Technical specifications

	220 GSE	250 GSE	275 GSE
diametro lama, diameter of the blade, Klingedurchmesser, diametre de la lame, diametro de la cuchilla	220 mm	250 mm	275 mm
motore, motor, Motor, moteur, motor	0,19 (0,25) kW (HP)	0,22 (0,30) kW (HP)	0,22 (0,30) kW (HP)
corsa carrello, carriage Stroke, Schillitenweglauf, course du chariot, carrera del carro	245 mm	270 mm	270 mm
ampiezza taglio, cut, Schnittgröße, ampleur de coupe, amplitud de corte \emptyset	160 mm	190 mm	210 mm
ampiezza taglio, cut, Schnittgröße, ampleur de coupe, amplitud de corte ∇	160x190 mm	190x220 mm	210x220 mm
spessore taglio, cut thickness, Schnittstärke, epaisseur de coupe, espesor de corte	0/15 mm	0/16 mm	0/16 mm
peso netto, net weight, Nettogewicht, poids net, peso neto	13 kg	16 kg	17 kg

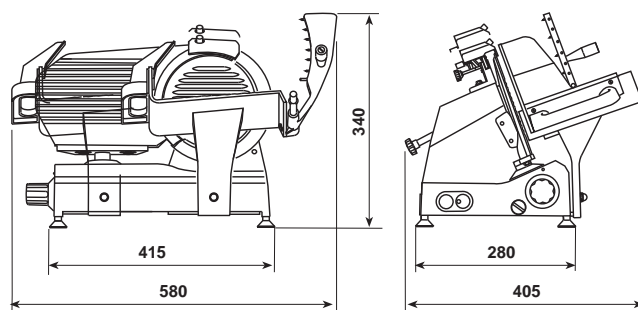

mod. 220 GSE

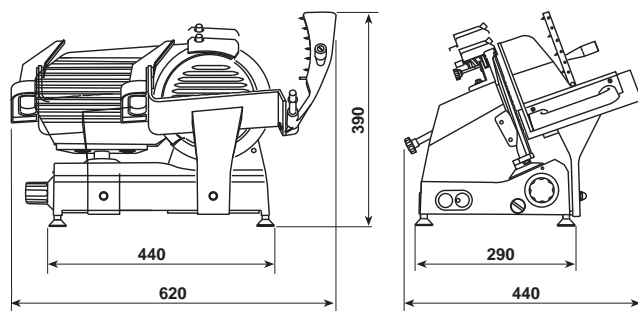

mod. 250 GSE /275 GSE



Nota: i dati del presente catalogo non sono impegnativi e potranno subire variazioni senza preavviso / Specifications and other features are subject to change without notice (02/10)